



INTERNATIONAL APPLICATION PUBLISHED UNDER THE PATENT COOPERATION TREATY (PCT)

BEST AVAILABLE COPY

<p>(51) International Patent Classification 7 : E21B 23/01, 43/10, 33/12, 23/02</p>	<p>A1</p>	<p>(11) International Publication Number: WO 00/26501 (43) International Publication Date: 11 May 2000 (11.05.00)</p>
<p>(21) International Application Number: PCT/EP99/08689 (22) International Filing Date: 1 November 1999 (01.11.99) (30) Priority Data: 98710015.3 4 November 1998 (04.11.98) EP (71) Applicant (for all designated States except CA US): SHELL INTERNATIONALE RESEARCH MAATSCHAPPIJ B.V. [NL/NL]; Carel van Bylandtlaan 30, NL-2596 HR The Hague (NL). (71) Applicant (for CA only): SHELL CANADA LIMITED [CA/CA]; 400 - 4th Avenue S.W., Calgary, Alberta T2P 2H5 (CA). (72) Inventor; and (75) Inventor/Applicant (for US only): HEUNEN, Wilhelmus, Hubertus, Paulus, Maria [NL/DE]; Elwerathstrasse 1, D-29336 Nienhagen (DE).</p>	<p>(81) Designated States: AE, AL, AM, AT, AU, AZ, BA, BB, BG, BR, BY, CA, CH, CN, CR, CU, CZ, DE, DK, DM, EE, ES, FI, GB, GD, GE, GH, GM, HR, HU, ID, IL, IN, IS, JP, KE, KG, KP, KR, KZ, LC, LK, LR, LS, LT, LU, LV, MA, MD, MG, MK, MN, MW, MX, NO, NZ, PL, PT, RO, RU, SD, SE, SG, SI, SK, SL, TJ, TM, TR, TT, TZ, UA, UG, US, UZ, VN, YU, ZA, ZW, ARIPO patent (GH, GM, KE, LS, MW, SD, SL, SZ, TZ, UG, ZW), Eurasian patent (AM, AZ, BY, KG, KZ, MD, RU, TJ, TM), European patent (AT, BE, CH, CY, DE, DK, ES, FI, FR, GB, GR, IE, IT, LU, MC, NL, PT, SE), OAPI patent (BF, BJ, CF, CG, CI, CM, GA, GN, GW, ML, MR, NE, SN, TD, TO).</p> <p>Published With international search report. Before the expiration of the time limit for amending the claims and to be republished in the event of the receipt of amendments.</p>	
<p>(54) Title: WELLBORE SYSTEM INCLUDING A CONDUIT AND AN EXPANDABLE DEVICE</p>		
<p>(57) Abstract</p>		

A system is provided including a conduit having a longitudinal axis, and a device (30) which is radially expandable relative to the conduit from a retracted mode whereby the device is radially spaced from the conduit, to an expanded mode whereby the device is radially expanded against the conduit. The device includes a shape memory metal element transformable from a first shape to a second shape upon reaching a selected temperature, the shape memory metal element being arranged to expand the device from the retracted mode to the expanded mode upon transformation of the memory metal element from the first shape to the second shape.

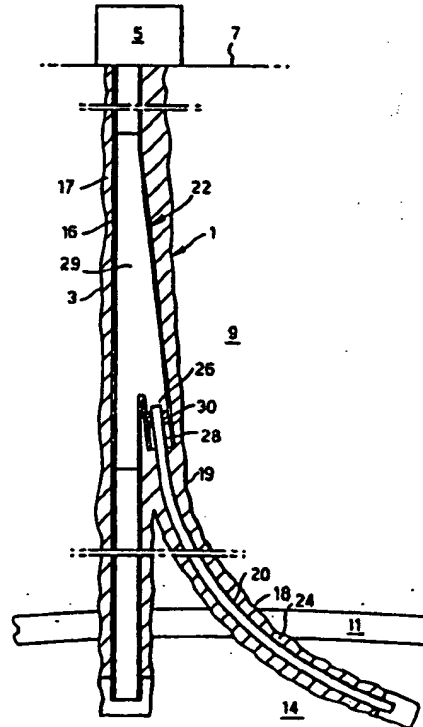

FOR THE PURPOSES OF INFORMATION ONLY

Codes used to identify States party to the PCT on the front pages of pamphlets publishing international applications under the PCT.

AL	Albania	ES	Spain	LS	Lesotho	SI	Slovenia
AM	Armenia	FI	Finland	LT	Lithuania	SK	Slovakia
AT	Austria	FR	France	LU	Luxembourg	SN	Senegal
AU	Australia	GA	Gabon	LV	Latvia	SZ	Swaziland
AZ	Azerbaijan	GB	United Kingdom	MC	Monaco	TD	Chad
BA	Bosnia and Herzegovina	GE	Georgia	MD	Republic of Moldova	TG	Togo
BB	Barbados	GH	Ghana	MG	Madagascar	TJ	Tajikistan
BE	Belgium	GN	Guinea	MK	The former Yugoslav Republic of Macedonia	TM	Turkmenistan
BF	Burkina Faso	GR	Greece	ML	Mali	TR	Turkey
BG	Bulgaria	HU	Hungary	MN	Mongolia	TT	Trinidad and Tobago
BJ	Benin	IE	Ireland	MR	Mauritania	UA	Ukraine
BR	Brazil	IL	Israel	MW	Malawi	UG	Uganda
BY	Belarus	IS	Iceland	MX	Mexico	US	United States of America
CA	Canada	IT	Italy	NE	Niger	UZ	Uzbekistan
CF	Central African Republic	JP	Japan	NL	Netherlands	VN	Viet Nam
CC	Congo	KE	Kenya	NO	Norway	YU	Yugoslavia
CH	Switzerland	KG	Kyrgyzstan	NZ	New Zealand	ZW	Zimbabwe
CI	Côte d'Ivoire	KP	Democratic People's Republic of Korea	PL	Poland		
CM	Cameroon	KR	Republic of Korea	PT	Portugal		
CN	China	KZ	Kazakhstan	RO	Romania		
CU	Cuba	LC	Saint Lucia	RU	Russian Federation		
CZ	Czech Republic	LJ	Liechtenstein	SD	Sudan		
DE	Germany	LK	Sri Lanka	SE	Sweden		
DK	Denmark	LR	Liberia	SG	Singapore		
EE	Estonia						



INTERNATIONAL APPLICATION PUBLISHED UNDER THE PATENT COOPERATION TREATY (PCT)

<p>(51) International Patent Classification ⁷ : E21B 23/01, 43/10, 33/12, 23/02</p>	<p>A1</p>	<p>(11) International Publication Number: WO 00/26501 (43) International Publication Date: 11 May 2000 (11.05.00)</p>
<p>(21) International Application Number: PCT/EP99/08689 (22) International Filing Date: 1 November 1999 (01.11.99) (30) Priority Data: 98710015.3 4 November 1998 (04.11.98) EP (71) Applicant (for all designated States except CA US): SHELL INTERNATIONALE RESEARCH MAATSCHAPPIJ B.V. [NL/NL]; Carel van Bylandilaan 30, NL-2596 HR The Hague (NL). (71) Applicant (for CA only): SHELL CANADA LIMITED [CA/CA]; 400 - 4th Avenue S.W., Calgary, Alberta T2P 2H5 (CA). (72) Inventor; and (75) Inventor/Applicant (for US only): HEIJNEN, Wilhelmus, Hubertus, Paulus, Maria [NL/DE]; Elwcrathstrasse 1, D-29336 Niehagen (DE).</p>	<p>(81) Designated States: AE, AL, AM, AT, AU, AZ, BA, BB, BG, BR, BY, CA, CH, CN, CR, CU, CZ, DE, DK, DM, EE, ES, FI, GB, GD, GE, GH, GM, HR, HU, ID, IL, IN, IS, JP, KE, KG, KP, KR, KZ, LC, LK, LR, LS, LT, LU, LV, MA, MD, MG, MK, MN, MW, MX, NO, NZ, PL, PT, RO, RU, SD, SE, SG, SI, SK, SL, TJ, TM, TR, TT, TZ, UA, UG, US, UZ, VN, YU, ZA, ZW, ARIPO patent (GH, GM, KE, LS, MW, SD, SL, SZ, TZ, UG, ZW), Eurasian patent (AM, AZ, BY, KG, KZ, MD, RU, TJ, TM), European patent (AT, BE, CH, CY, DE, DK, ES, FI, FR, GB, GR, IE, IT, LU, MC, NL, PT, SE), OAPI patent (BF, BJ, CF, CG, CI, CM, GA, GN, GW, ML, MR, NE, SN, TD, TG).</p> <p>Published With international search report. Before the expiration of the time limit for amending the claims and to be republished in the event of the receipt of amendments.</p>	

(54) Title: WELLBORE SYSTEM INCLUDING A CONDUIT AND AN EXPANDABLE DEVICE

(57) Abstract

A system is provided including a conduit having a longitudinal axis, and a device (30) which is radially expandable relative to the conduit from a retracted mode whereby the device is radially spaced from the conduit, to an expanded mode whereby the device is radially expanded against the conduit. The device includes a shape memory metal element transformable from a first shape to a second shape upon reaching a selected temperature, the shape memory metal element being arranged to expand the device from the retracted mode to the expanded mode upon transformation of the memory metal element from the first shape to the second shape.

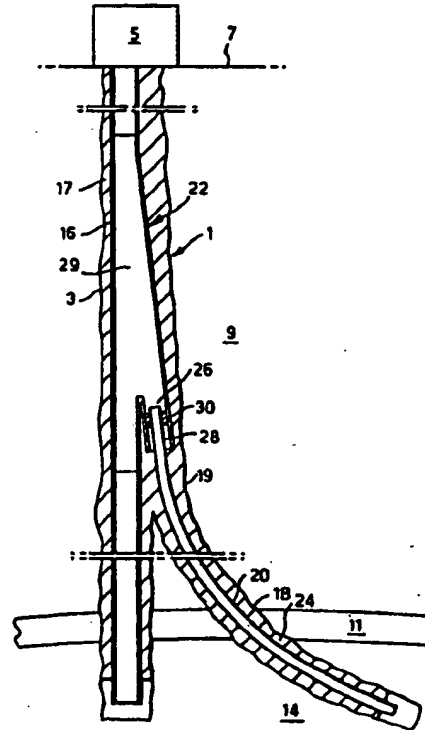

WELLBORE SYSTEM INCLUDING A CONDUIT AND AN EXPANDABLE DEVICE

The present invention relates to a system including a conduit having a longitudinal axis, and a device which is radially expandable relative to the conduit from a retracted mode whereby the device is radially spaced from the conduit, to an expanded mode whereby the device is radially expanded against the conduit. Systems of this kind are used, for example, in the industry of hydrocarbon production from the earth formation whereby expandable devices such as expandable packers or expandable anchors are applied in wellbore tubulars. A problem frequently occurring in such applications relates to the generally contradicting operational requirements for the expandable devices. Namely, in the retracted mode the device must be freely movable relative to the conduit in order to install the device at the desired location, and in the expanded mode the device must provide sufficient axial holding power (for e.g. wellbore packers) or sealing capacity (for wellbore seals). The problem is even more pronounced for applications in which the device is to be installed at remote locations.

It is an object of the invention to provide an improved expandable system which can be adequately radially expanded from a retracted mode to an expanded mode relative to a conduit, even at remote locations, and which provides adequate axial holding power and/or sealing capacity for high pressure applications.

In accordance with the invention there is provided a system including a conduit having a longitudinal axis, and a device which is radially expandable relative to the conduit from a retracted mode whereby the device is radially spaced from the conduit, to an expanded mode

whereby the device is radially expanded against the conduit, wherein the device includes a shape memory metal element transformable from a first shape to a second shape upon reaching a selected temperature, the shape memory metal element being arranged to expand the device from the retracted mode to the expanded mode upon transformation of the memory metal element from the first shape to the second shape.

When the device is in the retracted mode, the spacing between the device and the conduit allows axial movement of the device relative to the conduit during installation of the device. By subsequently heating or cooling of the memory metal element so that the temperature of the memory metal element reaches the selected temperature, the memory metal element transforms from the first shape to the second shape and thereby expands the device from the retracted mode to the expanded mode. Furthermore, no complicated remote controlled expansion equipment is needed to expand the device, only a heating or cooling source is applied. The memory metal element is capable of providing a large force upon transformation so that adequate holding power can be achieved and/or, when the device and the conduit are made of metal, a reliable metal-to-metal seal is achieved by the expansion of the device against the conduit.

Suitably said conduit is one of an outer conduit and an inner conduit extending coaxially into the outer conduit whereby an annular space is defined between the outer conduit and the inner conduit, and wherein the expandable device forms a sealing device arranged in said annular space, which sealing device in the radially expanded mode thereof is expanded against said inner conduit and against said outer conduit.

In an attractive embodiment the system further includes a branched wellbore system formed in an earth

5 formation, the branched wellbore system comprising a main wellbore provided with a main casing, a branch wellbore provided with a branch casing, and a casing junction member having a main bore and a branch bore in fluid communication with the main bore, the main bore being an extension of the main casing, the branch bore being an extension of the branch casing, and wherein said inner conduit is formed by the branch casing and the outer conduit is formed by the branch bore. This embodiment is particularly attractive as it provides an adequate solution to the problem of sealing of wellbore junctions of multilateral wellbore systems.

10 US patent No. 5,318,122 discloses a Y-shaped casing junction member which connects a casing of a main wellbore to a liner installed in a branch wellbore, the casing junction member having a branch member into which an end part of the liner extends with a seal between said end part and the branch member. However a problem of the known system is that a reliable seal which is capable of withstanding the high wellbore pressures generally encountered, is not available. Therefore the known casing junction has to be positioned relatively deep in the main wellbore, i.e. in the reservoir zone or in the cap rock overlaying the reservoir zone, where the fluid pressure difference between the interior and the exterior of the casing is relatively low and where leaks are unimportant. In this respect it is noted that the cap rock layer has sufficient low permeability to prevent migration of fluids from the reservoir zone to the overburden layer above the cap rock.

25
30
35 In contrast thereto the system according to the invention allows the casing junction member to be positioned anywhere, and preferably relatively high in the main wellbore, i.e. in the overburden layer. This is advantageous because the branch wellbore then starts

deviating from the main wellbore relatively high in the earth formation so that, for a given maximum curvature of the branch wellbore, the lower end of the branch wellbore can be drilled to a larger horizontal distance from the main wellbore than in a conventional situation where the junction between the main wellbore and the branch wellbore is located in the reservoir zone or the cap rock layer. Thus, by virtue of the large sealing capacity achieved with the system according to the invention the junction between the main wellbore and the branch wellbore can be positioned in the overburden layer where the difference between the pore pressure in the overburden layer and the pressure of hydrocarbon fluid flowing through the wellbore system, is high.

It is preferred that the sealing device in the expanded position thereof provides a metal-to-metal seal.

In another attractive embodiment, the device is an anchoring device arranged within the conduit and adapted to be anchored to the inner surface of the conduit when in the radially expanded mode.

The invention will be described hereinafter by way of example in more detail with reference to the accompanying drawings in which:

Fig. 1 schematically shows an embodiment of a wellbore system according to the invention;

Fig. 2 schematically shows a casing junction member of the system of Fig. 1;

Fig. 2A schematically shows transverse cross-section along line 2A-2A of Fig. 2;

Fig. 2B schematically shows transverse cross-section along line 2B-2B of Fig. 2;

Fig. 3 schematically shows the casing junction member of Fig. 2 in a sealed mode;

Fig. 4 schematically shows detail A of Fig. 3; and

Fig. 5 schematically shows a further embodiment of the wellbore system according to the invention.

Referring to Fig. 1 there is shown a wellbore system 1 including a main wellbore 3 extending from a wellhead 5 at the earth surface 7 through an overburden layer 9 and a cap rock layer 11 to a reservoir zone 14 which contains a hydrocarbon fluid. The cap rock layer 11 is relatively tight and prevents migration of the high pressure hydrocarbon fluid from the reservoir zone 14 to the overburden layer 9.

The main wellbore 3 is provided with a tubular steel main casing 16 which is fixed and sealed into the main wellbore 3 by a layer of cement 17 and which has an open lower end. A branch wellbore 18 extends from a wellbore junction 19 located in the overburden layer 9, through the overburden layer 9 and the cap rock layer 11, into the reservoir zone 14. The branch wellbore 18 is provided with a branch casing 20 having an open lower end and being connected to the main casing 16 by a casing junction member 22 in a sealing relationship therewith as described below. The casing junction member 22 is located at the wellbore junction 19, i.e. in the overburden layer 9. The branch casing 20 is sealed into the branch wellbore 18 by a layer of cement 24. Alternatively the branch casing can be sealed in the branch wellbore by any suitable means such as by sealing packers.

Referring further to Figs. 2, 2A, 2B and 3, the casing junction member 22 has a tubular main bore 24 having longitudinal axis 24a, the main bore 24 being aligned with the main casing 16, and a tubular branch bore 26 having longitudinal axis 26a. The branch casing 20 extends into the branch bore 26 with an annular space 28 therebetween. An annular sealing device 30 is arranged in the space 28, which sealing device 30 is movable between a radially retracted mode and a radially

expanded mode. In the retracted mode the sealing device is radially spaced from the branch bore 26 and from the branch casing 20 as shown in Fig. 2. In the expanded mode the sealing device 30 is expanded against the branch bore 26 and the branch casing 20 as shown in Fig. 3.

The casing junction member 22 is a monolithic structure and has a generally circular transverse cross-section, as shown in Figs. 2A and 2B. Such structure and shape provide adequate collapse resistance to the casing junction member 22, which should not be less than the collapse resistance of the main casing 16.

In Fig. 4 is shown detail A of Fig. 3. The sealing device 30 includes a metal annular body 34 having two sealing rings 36a, 36b and an annular wedge 38 which is arranged between the sealing rings 36a, 36b and is in operative relationship therewith so as to radially press sealing ring 36a against the branch bore 26 and sealing ring 36b against the branch casing 20 upon axial movement of the wedge 38 into the annular body 34. The contact surfaces between the wedge 38 and the sealing rings 36a, 36b are serrated so that the wedge becomes locked to the sealing rings once such inward axial movement has occurred. A number of circumferentially spaced rods 40 extend through corresponding holes 41 provided in the wedge 38, each rod having a threaded end 40a connecting the rod to the annular body 34 and a T-shaped head 40b at the other end. The rods 40 are made of shape memory metal and assume an axially extended shape below a selected transition temperature and an axially retracted shape above the transition temperature. In the axially extended shape, the wedge 38 is in an initial position whereby sealing ring 36a is radially spaced from the surface of the branch bore 26 and sealing ring 36b is radially spaced from the outer surface of the branch casing 20. In the axially retracted shape of the rods 40, the wedge 38

is pulled by the rods between the sealing rings 36a, 36b whereby sealing ring 36a becomes pressed against the surface of the branch bore 26 and ring 36b against outer surface of the branch casing 20 so as to form a metal-to-metal seal between the branch bore 26 and the branch casing 20. Annular body 34 is connected to a lock nut 42 by a bearing 44 which allows rotation of the lock nut 42 relative to the body 34 about longitudinal axis 26a. Lock nut 42 is connected to the branch casing 20 by screw connection 46.

Fig. 4 furthermore shows a locking and centralising assembly 48 arranged between the branch bore 26 and the branch casing 20, the assembly 48 including a self-expanding lock ring 50 which is supported on a shape memory metal actuator ring 52 which in turn is supported on a tapered landing ring 54. The landing ring 54 rests against an annular shoulder 55 provided at branch casing 20 and has an outer annular groove 56 in which a split actuator ring 58 of shape memory metal is arranged. The assembly 48 is retained between an annular retaining ring 60 and an annular shoulder 62 provided at the outer surface of the branch casing 20. The retaining ring 60 can be shrink fitted, screwed, snap fitted or welded to the branch casing 20. The actuator ring 52 assumes an axially retracted shape below a selected transition temperature and an axially extended shape above the transition temperature. The split actuator ring 58 assumes a radially retracted shape below the selected transition temperature and a radially extended shape above the transition temperature. An annular groove 64 is provided in the branch bore 26, into which the assembly 48 fits with some axial and radial clearance if the actuator rings 52, 58 are below their transition temperature. If the actuator rings 52, 58 are above their transition temperature the lock ring 50 is pressed

against shoulder 62 by the axially expanded actuator ring 52, and the landing ring 54 is centralised in the branch bore 26 by the radially expanded actuator ring 58. The transition temperature of the actuator rings 52, 58 is selected slightly below the transition temperature of the rods 40.

During normal operation of the wellbore system 1, the main wellbore 3 is drilled and the main casing 16 with the casing junction member 22 incorporated therein is lowered and cemented into the main wellbore 3. During the installation and cementing procedure the branch bore 26 is at the lower end thereof closed by a plug (not shown) which can be drilled out. A whipstock (not shown) is then positioned in the main casing 16 and casing junction member 22 so as to direct a drill string (not shown) into the branch bore 26. A removable wear bushing (not shown) is temporarily arranged in the branch bore 26 to prevent contact of the drill string with the surface of the branch bore 26. The drill string is then lowered through the main casing 16 and guided by the whipstock into the branch bore 26. The drill string is rotated to drill out the plug and to drill the branch wellbore 18. After completing the drilling operation the wear bushing is removed from branch bore 26 and the branch casing 20 is lowered through the main casing 16 and guided by the whipstock (or by any other suitable guiding means) into the branch wellbore 18 until the self-expanding lock ring 50 latches into annular groove 64. The branch casing is supported by landing ring 54 and shoulder 55.

The sealing device 30 is lowered through the main casing 16 and guided into branch bore 26 whereby the annular body 34 enters the annular space 28 until lock nut 42 arrives at the upper end of the branch casing 20. The lock nut 42 is then screwed to the branch casing using a suitable setting tool (not shown) whereby the

bearing 44 allows the annular body 34 to be non-rotating while the lock nut is rotated. By virtue of the design of the sealing device 30, the wedge 38 and sealing rings 36a, 36b are accurately positioned in the annular space 28. Reversal of the above procedure using the setting tool allows the sealing device 30 to be withdrawn from the annular space 28, for example to install a new seal.

A heating device (not shown) is lowered through the main casing 16 and guided into branch bore 26. Heat is transferred from the heating device to the shape memory metal elements 52, 58 and 40. Upon reaching their respective transition temperature actuator ring 52 expands axially and actuator ring 58 expands radially thereby axially locking and centralising branch casing 20 in branch bore 26. The rods 40 axially retract upon reaching their respective transition temperature and thereby pull wedge 38 between the sealing rings 36a, 36b whereby ring 36a becomes pressed against the surface of the branch bore 26 and ring 36b against the outer surface of the branch casing 20 so as to form a metal-to-metal seal between the branch bore 26 and the branch casing 20. The wedge 38 becomes locked to the rings 36a, 36b by virtue of the serrated contact surfaces between the wedge 38 and the rings 36a, 36b. As the heating device is turned off and the temperature of the rods 40 drops below the transition temperature thereof, the rods axially expand through the respective holes 41 of wedge 38 while the wedge remains locked to the sealing rings. Cement is pumped between the branch casing 20 and the branch borehole 18 to form cement layer 24 which seals the branch casing in the branch borehole 18.

After completion of wellbore system 1, production of hydrocarbon fluid, e.g. high pressure natural gas, from the reservoir zone 14 is commenced. The fluid flows from

the reservoir zone 14 into the main casing 16 and the branch casing 20 and through these casings to the wellhead 5 from where the fluid is further transported to a suitable processing facility (not shown). The metal-to-metal-seal provided by sealing device 30 prevents leakage of fluids through annular space 28 to the overburden layer 9. Cement layers 17 and 24 seal the main casing 16 and the branch casing 20 in their respective wellbores so that leakage of gas from the reservoir zone 14 along the casings 16, 20 to the overburden layer 9 also is prevented. In this manner it is achieved that gas is produced through the casings 16, 20 without the need for conventional production tubings, and without the risk of gas leaking from the reservoir zone 14 to the overburden layer 9.

Another advantage of the system of the invention is the option of including a secondary conduit extending from the wellhead (which is provided with a blow out preventer) through the main casing and into the branch bore of the casing junction member in a sealing relationship with said branch bore. The secondary conduit can be, for example, a hydrocarbon fluid production conduit for separate production of hydrocarbon fluid from the branch wellbore and main wellbore e.g. in case of a high fluid pressure difference between the main wellbore and the branch wellbore. Alternatively, the secondary conduit can be a service liner for guiding a wellbore tool from the earth surface into the branch wellbore, such as a drill string for further drilling of the branch wellbore. An advantage of the application of such service liner is that fluid production through the main wellbore is continued while wellbore operations in the branch wellbore are carried through the service liner which isolates such operations from the remainder of the main wellbore and any other branch wellbores thereof. The

secondary conduit is preferably provided with a latching mechanism which latches into the branch bore.

5 Optionally the branch casing can be provided in its upper end part with a flow control valve which is retrievable to surface by wireline or coiled tubing. The flow control valve controls the flow of hydrocarbon fluid through the branch casing and is operated by telemetry or by a selected property of the fluid under control.

10 Furthermore, a safety valve can be installed in the far end part of the branch casing which operates by telemetry or by a property of the fluid under control, for example a selected fluid pressure difference across the safety valve.

15 The flow control valve and the safety valve each have a reverse flow bypass which permits the reverse flow of fluids upon the occurrence of a selected reverse fluid pressure difference across the valve.

20 Referring to Fig. 5 there is shown an anchoring device 68 arranged within a conduit 70 arranged in a wellbore (not shown) and having longitudinal axis 71. The anchoring device is radially expandable relative to the conduit 70 from a retracted mode whereby the device 68 is radially spaced from the conduit 70, to an expanded mode whereby the device 68 is radially expanded against the conduit 70. The anchoring device 68 includes a
25 cylindrical body 72 which fits longitudinally in the conduit 70 and radially deformable annular anchors 74, 76 which are arranged at opposite ends of the cylindrical body 72. A wedge-shaped annular expander ring 78 fits within anchor 74 and a similar wedge-shaped expander ring 80 fits within anchor 76. The expander rings 78, 80
30 are interconnected by a plurality of circumferentially spaced rods 82 made of shape memory metal. Each rod 82 extends through a corresponding bore 84 provided in expander 78 and has a T-shaped head 86 at the outer end
35

of the bore 84, and is connected to expander 80 by a screw connection 88. The contact surface between the expander ring 78 and the anchor 74, and the contact surface between the expander ring 80 and the anchor 76 are serrated so as to lock the expander rings 78, 80 to the respective anchors 74, 76 upon inward axial movement of the expander rings 78, 80. The rods 82 are transformable from an extended shape below a selected transition temperature to an retracted shape above the selected temperature. In the extended shape of the rods 82, the expander rings 78, 80 are at an initial axial distance whereby the anchors 74, 76 are radially spaced from the inner surface of the conduit 70. Upon transformation of the rods 82 to the retracted shape, the rods 82 axially pull the expander rings 78, 80 towards each other thereby radially deforming the anchors 74, 76 against the inner surface of the conduit 70 which thereby become locked against the conduit 70.

During normal operation a heater is lowered in the cylindrical body 72 and operated so as to raise the temperature of the rods 82 to the transition temperature whereupon the rods retract so as to pull the expander rings 78, 80 towards each other and thereby radially expand the anchors 74, 76 against the inner surface of the conduit 70. The expander rings 78, 80 become locked to the respective anchors 74, 76 by virtue of the serrated contact surfaces. The rods 82 can expand freely through bores 84 when the temperature of the rods drops again below the transition temperature.

Referring to Figs 1-5, instead of the main wellbore and the branch wellbore producing from a single reservoir zone, these wellbores can produce from mutually spaced reservoir zones.

The above detailed description refers to a main wellbore and one branch wellbore for the sake of

simplicity. It will be clear that the invention can equally be applied for a plurality of branch wellbores.

5 Instead of the casing junction member being a monolithic structure, it can be assembled from separate parts. Further, the cross-sectional shape of the junction member can be elliptical or polygonal instead of circular.

10 Further, instead of using memory metal elements which are to be heated to reach the transition temperature, memory metal elements can be applied which are to be cooled to reach their respective transition temperatures. In that case a cooling device is lowered into the wellbore system instead of a heating device.

C L A I M S

1. A system including a conduit having a longitudinal axis, and a device which is radially expandable relative to the conduit from a retracted mode whereby the device is radially spaced from the conduit, to an expanded mode whereby the device is radially expanded against the conduit, wherein the device includes a shape memory metal element transformable from a first shape to a second shape upon reaching a selected temperature, the shape memory metal element being arranged to expand the device from the retracted mode to the expanded mode upon transformation of the memory metal element from the first shape to the second shape.
2. The system of claim 1, wherein said conduit is one of an outer conduit and an inner conduit extending coaxially into the outer conduit whereby an annular space is defined between the outer conduit and the inner conduit, and wherein the expandable device forms a sealing device arranged in said annular space, which sealing device in the radially expanded mode thereof is expanded against said inner conduit and against said outer conduit.
3. The system of claim 2, further including a branched wellbore system formed in an earth formation, the branched wellbore system comprising a main wellbore provided with a main casing, a branch wellbore provided with a branch casing, and a casing junction member having a main bore and a branch bore in fluid communication with the main bore, the main bore being an extension of the main casing, the branch bore being an extension of the branch casing, and wherein said inner conduit is formed by the branch casing and the outer conduit is formed by the branch bore.

4. The system of claim 3, wherein the earth formation includes a hydrocarbon fluid reservoir zone, an overburden layer located above the reservoir zone and a cap rock layer located between the reservoir zone and the overburden layer, and wherein the casing junction member is located in the overburden layer.
5. The system of claim 3 or 4, further including a secondary conduit extending through said main casing and into said branch bore in a sealing relationship with the branch bore.
6. The system of claim 5, wherein the secondary conduit is one of a hydrocarbon fluid production conduit and a service conduit into which a wellbore tool for performing an operation in the branch wellbore extends.
7. The system of claim 6, wherein the secondary conduit is a service conduit through which a drill string extends so as to further drill the branch wellbore.
8. The system of any one of claims 2-7, wherein the sealing device in the retracted mode thereof is radially spaced from the outer conduit and from the inner conduit.
9. The system of any one of claims 2-8, further including a centralising device arranged in the annular space for centralising the inner conduit within the outer conduit.
10. The system of claim 9, wherein the centralising device is radially expandable from a retracted mode in which the centralising device is radially spaced from at least one of the outer and inner conduits, and an expanded mode in which the centralising device is radially expanded against the inner conduit and against the outer conduit so as to centralise the inner conduit within the outer conduit, the centralising device including a secondary shape memory metal element transformable from a third shape to a fourth shape upon reaching a selected transition temperature and being

arranged to expand the centralising device from the retracted mode to the expanded mode thereof upon transformation from the third to the fourth shape.

5 11. The system of any one of claims 2-10, wherein the sealing device in the expanded mode thereof provides a metal-to-metal seal between the inner conduit and the outer conduit.

10 12. The system of any one of claims 1-11, wherein the device includes a wedge shaped expander being arranged to radially expand the device upon a selected axial movement of the expander, and wherein the memory metal element is arranged to induce said selected axial movement to the expander upon transformation of the memory metal element from the first shape to the second shape thereof.

15 13. The system of claim 1, wherein the device is an anchoring device arranged within the conduit and adapted to be anchored to the inner surface of the conduit when in the radially expanded mode.

20 14. The system of claims 13, wherein said conduit forms part of a wellbore system formed in an earth formation.

15. The system substantially as described hereinbefore with reference to the drawings.

Fig.1.

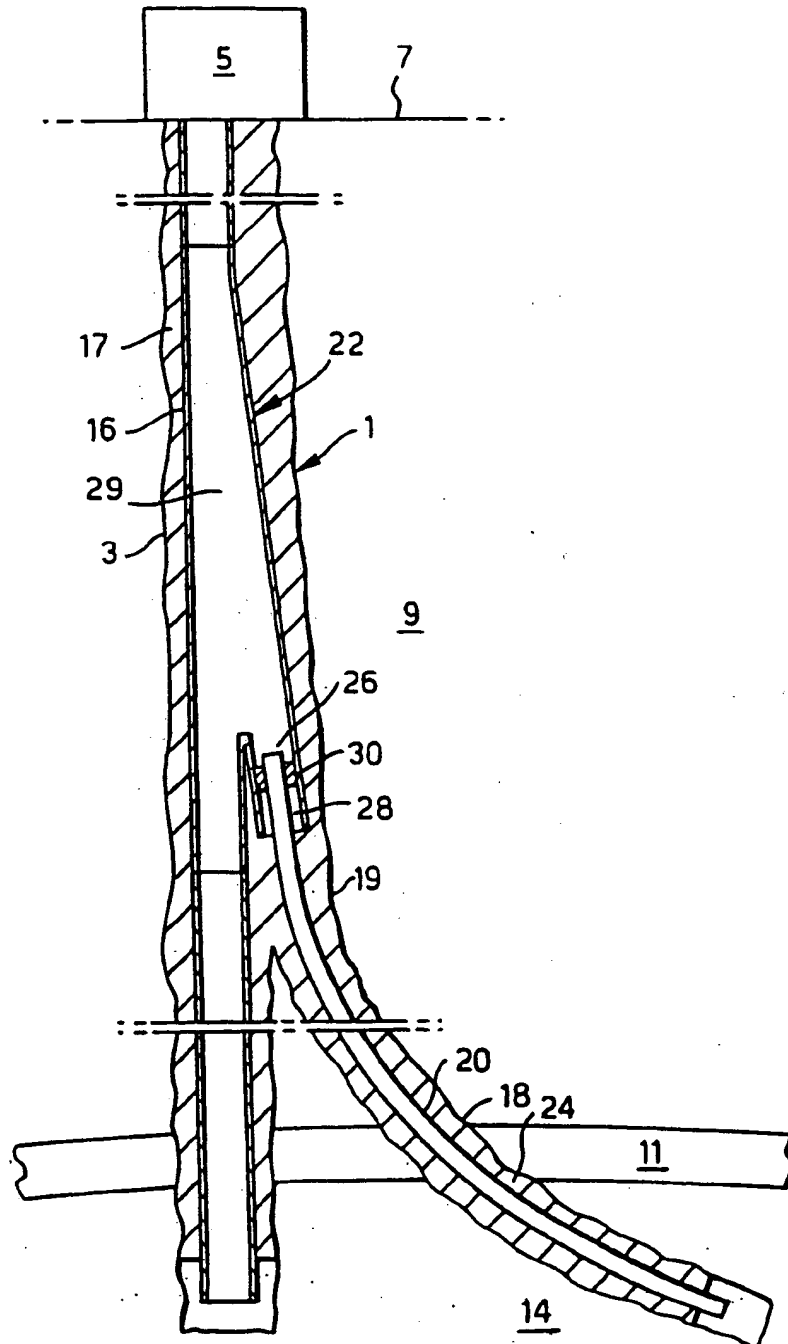

Fig.2.

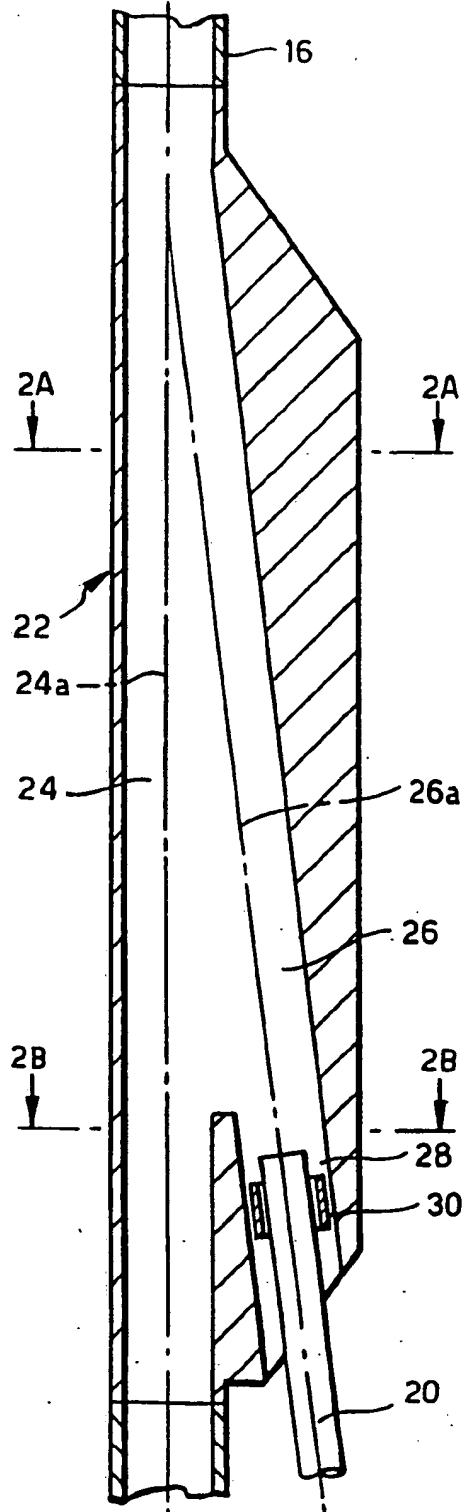

Fig.2A.

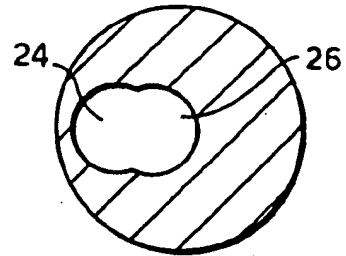
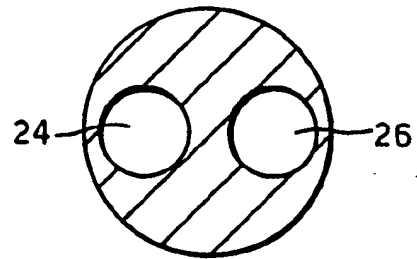

Fig.2B.



3/5

Fig.3.

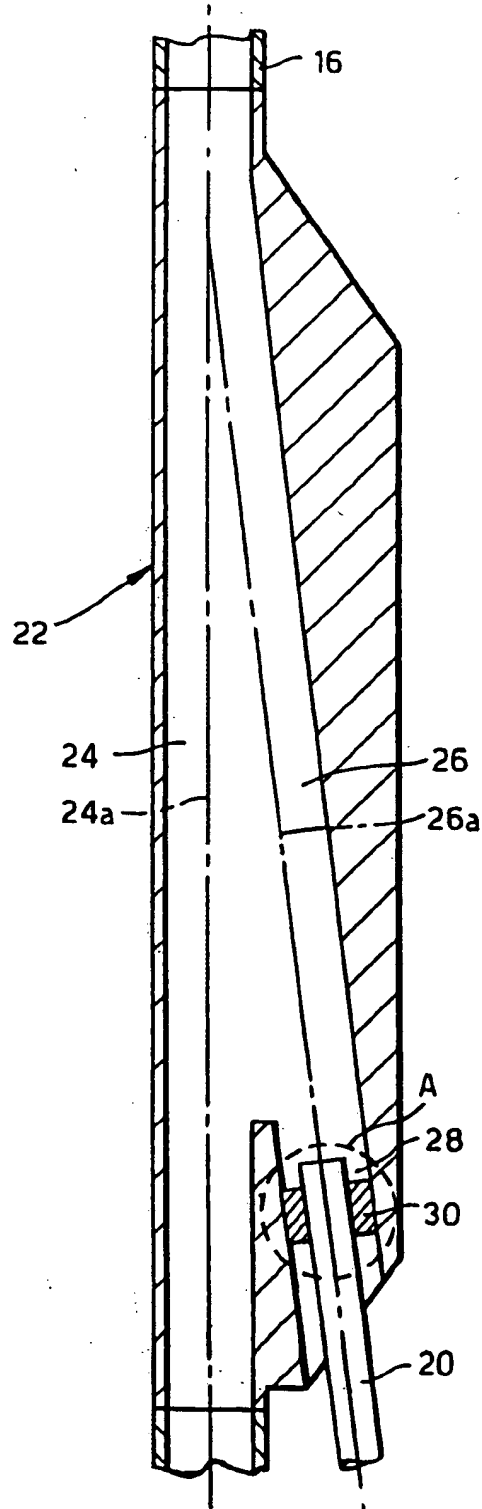

Fig.4.

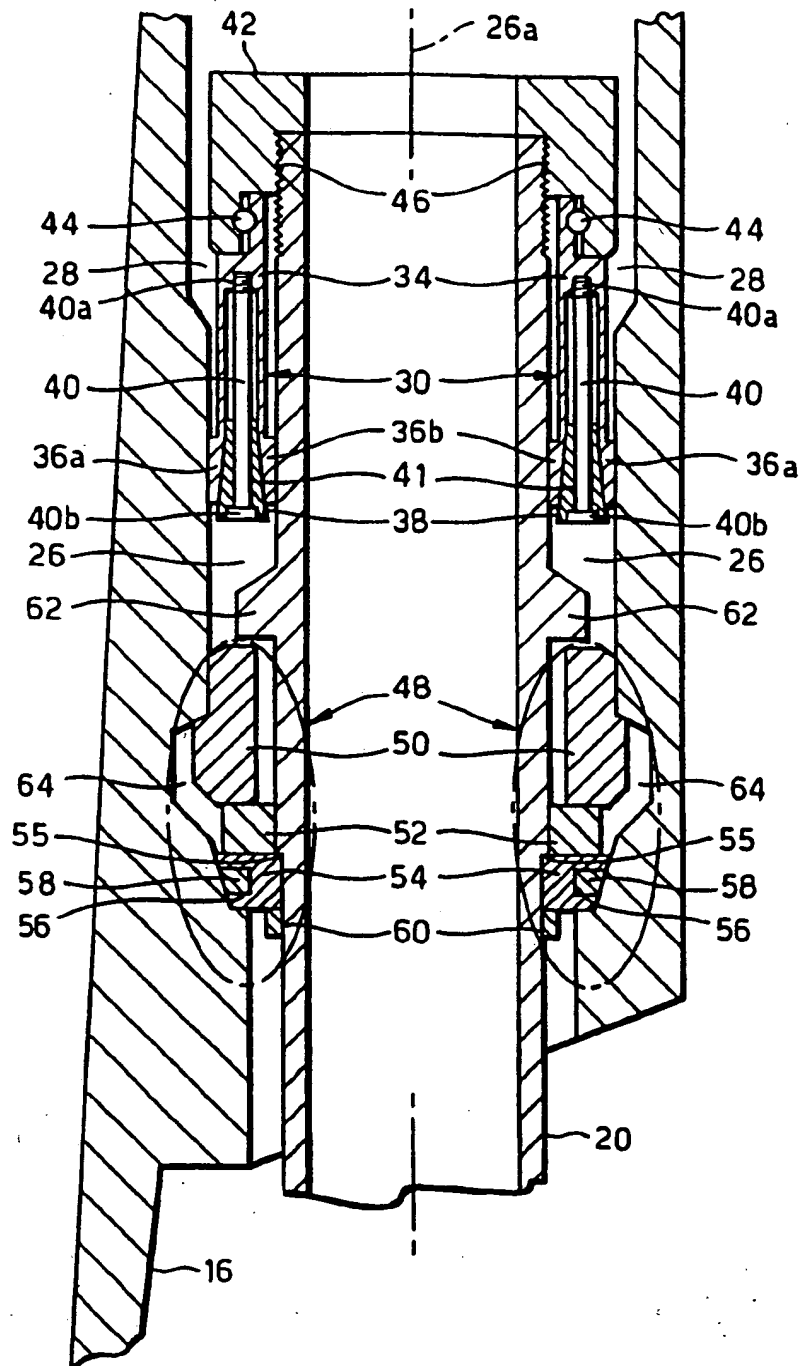
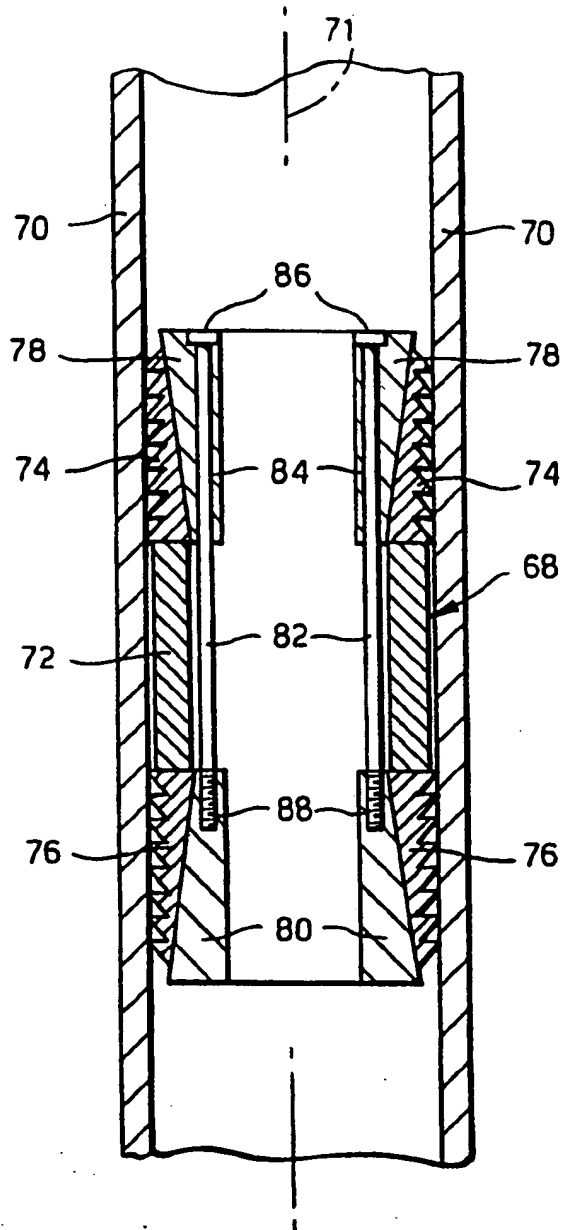

Fig.5.



INTERNATIONAL SEARCH REPORT

Intern. Appl. No.

PCT/EP 99/08689

A. CLASSIFICATION OF SUBJECT MATTER
 IPC 7 E21B23/01 E21B43/10 E21B33/12 E21B23/02

According to International Patent Classification (IPC) or to both national classification and IPC

B. FIELDS SEARCHED

Minimum documentation searched (classification system followed by classification symbols)
 IPC 7 E21B

Documentation searched other than minimum documentation to the extent that such documents are included in the fields searched

Electronic data base consulted during the international search (name of data base and, where practical, search terms used)

C. DOCUMENTS CONSIDERED TO BE RELEVANT

Category*	Citation of document, with indication, where appropriate, of the relevant passages	Relevant to claim No.
X	US 5 215 145 A (ROSS) 1 June 1993 (1993-06-01) abstract column 8, line 44 - line 58 column 3, line 16 - line 32	1, 2, 8, 11-15
Y	—	9
Y	US 5 253 705 A (CLARY) 19 October 1993 (1993-10-19) column 3, line 65 - column 4, line 2	9
X	US 5 318 122 A (MURRAY) 7 June 1994 (1994-06-07) cited in the application abstract; claims 11, 12	1-8, 11, 13-15
	-/-	

Further documents are listed in the continuation of box C. Patent family members are listed in annex.

* Special categories of cited documents:

<p>"X" document defining the general state of the art which is not considered to be of particular relevance</p> <p>"E" earlier document but published on or after the international filing date</p> <p>"L" document which may throw doubt on priority claim(s) or which is cited to establish the publication date of another citation or other special reason (as specified)</p> <p>"O" document referring to an oral disclosure, use, exhibition or other means</p> <p>"P" document published prior to the international filing date but later than the priority date claimed</p>	<p>"T" later document published after the international filing date or priority date and not in conflict with the application but cited to understand the principle or theory underlying the invention</p> <p>"C" document of particular relevance; the claimed invention cannot be considered novel or cannot be considered to involve an inventive step when the document is taken alone</p> <p>"M" document of particular relevance; the claimed invention cannot be considered to involve an inventive step when the document is combined with one or more other such documents, such combination being obvious to a person skilled in the art</p> <p>"A" document member of the same patent family</p>
---	---

Date of the actual completion of the international search	Date of mailing of the international search report
7 March 2000	14/03/2000

Name and mailing address of the ISA European Patent Office, P.O. Box 5818 Paternoster 2 NL - 2200 HV The Hague Tel. (+31-70) 840-2040, Tx. 81 651 spa nl, Fax (+31-70) 840-8018	Authorized officer Sogno, M
---	------------------------------------

INTERNATIONAL SEARCH REPORT

International Application No

PCT/EP 99/08689

C.(Continuation) DOCUMENTS CONSIDERED TO BE RELEVANT		
Category*	Citation of document, with indication, where appropriate, of the relevant passages	Relevant to claim No.
X	US 4 588 030 A (BLIZZARD) 13 May 1986 (1986-05-13) column 5, line 38 -column 6, line 4	1,2,8, 11-15
X	US 4 588 029 A (BLIZZARD) 13 May 1986 (1986-05-13) column 5, line 24 - line 42 column 3, line 22 - line 44	1,2,8, 11,13-15
X	US 4 515 213 A (ROGEN) 7 May 1985 (1985-05-07) column 7, line 57 -column 8, line 25	1,2,8, 11,13-15
X	US 5 040 283 A (PELGROM) 20 August 1991 (1991-08-20) claim 1	1,2,8, 11,13-15

INTERNATIONAL SEARCH REPORT

information on patent family members

Inter. Appl. Application No

PCT/EP 99/08689

Patent document cited in search report	Publication date	Patent family member(s)	Publication date
US 5215145 A	01-06-1993	NONE	
US 5253705 A	19-10-1993	NONE	
US 5318122 A	07-06-1994	AU 663277 B AU 4997993 A CA 2120368 A DE 4393849 T DK 38894 A GB 2275286 A,B NL 9320007 T NO 941238 A WO 9403701 A	28-09-1995 03-03-1994 17-02-1994 10-11-1994 06-06-1994 24-08-1994 01-11-1994 02-06-1994 17-02-1994
US 4588030 A	13-05-1986	NONE	
US 4588029 A	13-05-1986	NONE	
US 4515213 A	07-05-1985	NONE	
US 5040283 A	20-08-1991	CA 1320437 A CN 1040859 A,B EP 0360319 A NO 180460 B	20-07-1993 28-03-1990 28-03-1990 13-01-1997